

# MOUNTING GUIDELINES FOR RKB TQO/TQOS BEARINGS IN ROLLING MILL APPLICATIONS (BORE DIAMETER UP TO ABOUT 450 MM)

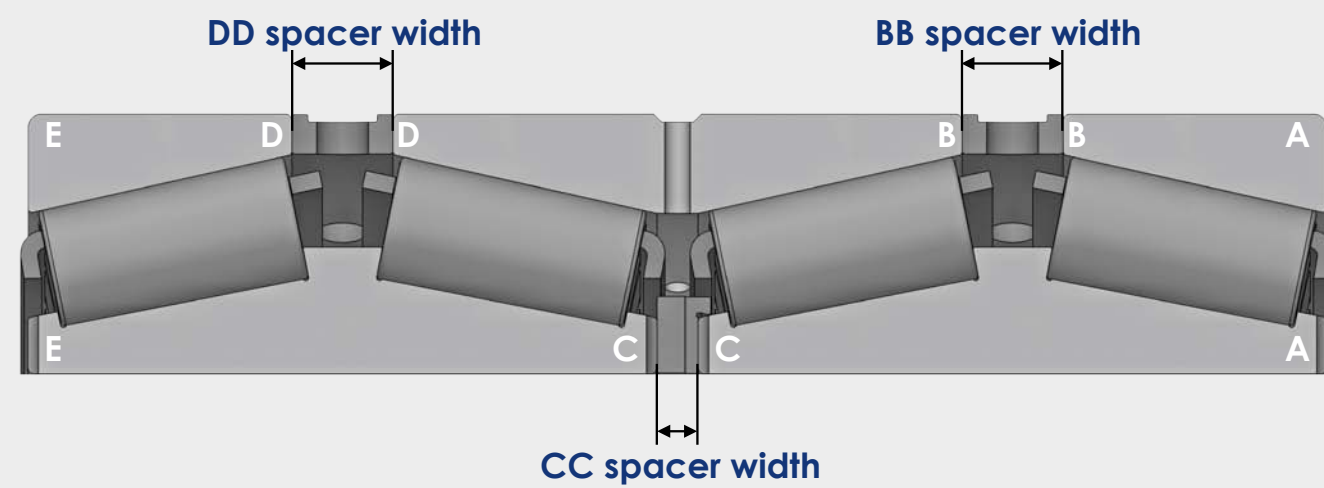

- RKB four-row taper roller bearings in TQO configuration are generally composed of two double cone assemblies (AC and CE), one central double cup (BD), two single cups (AB and DE) and three factory adjusted spacers: two cup spacers (BB and DD) and one cone spacer (CC).
- RKB TQO bearings may be manufactured in different configurations: with cylindrical/tapered bore, with/without seals, with/without helical grooves on cone bores and with/without spacers.
- The spacers are face ground after accurate measurements of the gaps between adjacent cups and cones to obtain the required initial axial clearance (B.E.P. - Bench End Play).
- Due to the special operating conditions (contaminated environments, high temperatures, presence of vibrations and shocks), adequate lubrication is required and the use of an effective sealing system is highly recommended.
- The TQOS version has seals fitted on both sides of the bearing, one cone seal set and O-type seal rings on the outer surfaces of the single cups.
- The mounting of the bearing onto the roll neck has to be in accordance with the mounting instructions supplied with the rolling mill machinery design.
- For bore diameters up to about 450 mm, the mounting has to be performed with the bearing assembled as shown in the procedures on the right.

## PRELIMINARY OPERATIONS

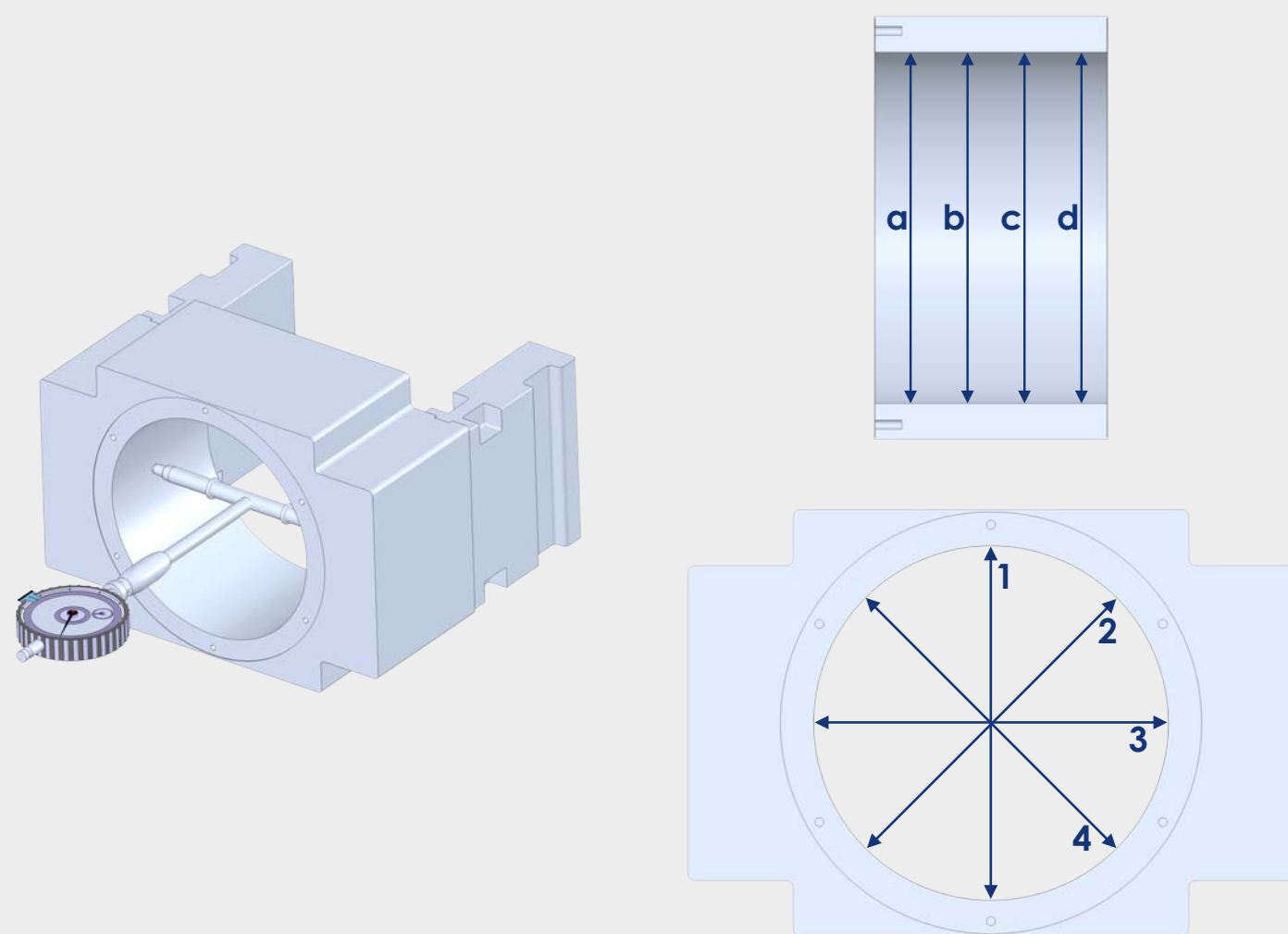

- Prior to mounting, measure the chock bore diameter in four equally spaced planes normal to the bore axis of symmetry (a, b, c, d) and in each plane in four directions offset at 45° (1, 2, 3, 4). These measurements have to be properly recorded.
- Carry out the same procedure for the shaft.
- Bore and shaft shape deviations are highly recommended to be measured as well.
- Properly lubricate bearing components according to the lubricant suggested in the rolling mill machinery design.
- For easy mounting, be sure that the chock and the shaft are clean and lubricated; this will reduce the wear and corrosion of the assembly elements during operation.

## UNSEALED BEARINGS (TQO)

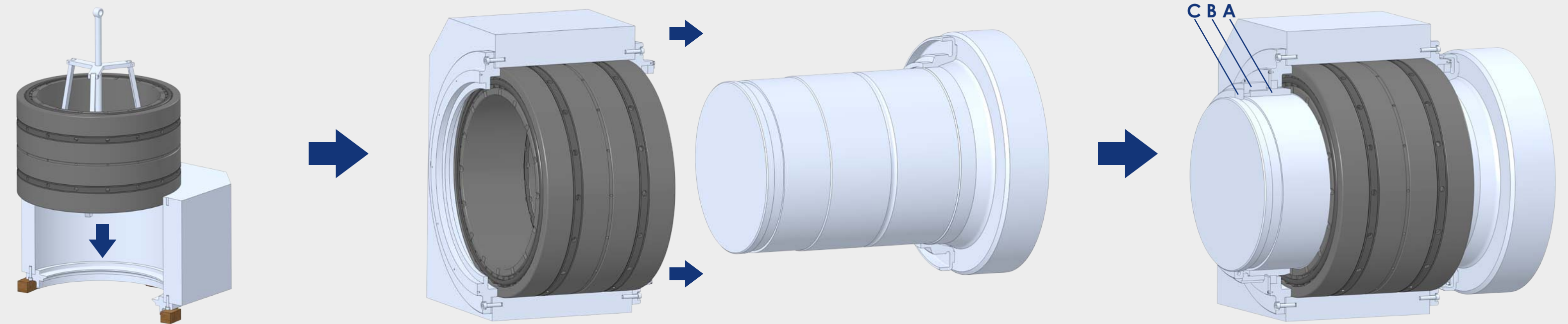

- Fasten the roll-side cover onto the chock.
- Place the chock on level supports with bore axis in vertical position.
- Use a lifting device to mount the bearing assembly into the chock with side E facing down.
- Check the seating of the bearing assembly against the cover shoulder with a feeler gauge.
- Mount the chock cover without gasket.
- Tighten evenly four equally spaced cap screws, until the cover is uniformly seated against the side face of the chock, and cups and cup spacers abut each other.
- Measure the width of the gap between the cover and the chock and establish the gasket or metallic shim set final thickness.

- Remove the cover, insert the gasket or metallic shim set of required thickness and mount the cover.
- Push the labyrinth ring (heated in an oil bath) onto the roll neck.
- Align the chock with the shaft.
- Mount the seal neighboring the shaft shoulder and push the chock onto the roll neck with side E forward until side E of the double cone abuts the labyrinth ring.
- Mount the remaining seal, spacer (A), nut (B) and split clamping ring (C) into position.
- Tighten the nut until it abuts the clamping ring and the spacer abuts the bearing cone.
- Loosen the nut in order to leave an appropriate axial clearance, which enables free cone rotation and prevents wear to the cone faces.

## SEALED BEARINGS (TQOS)

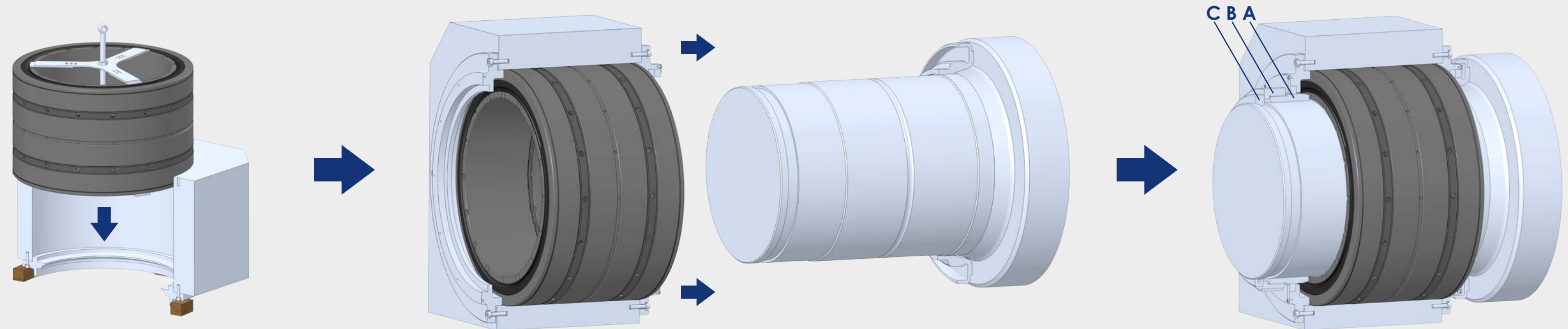

- Fasten the roll-side cover onto the chock (if need be, lay the O-type seal rings in position).
- Place the chock on level supports with bore axis in vertical position.
- On the special clamping/lifting device, complete the bearing assembly by placing the parts in the correct order; retract the upper arms of the clamping device so that they abut face A of the double cone AC.
- Lift the assembly with the special clamping/lifting device and lower it into the chock with side E facing down.
- Check the seating of the bearing assembly against the cover shoulder with a feeler gauge.
- Mount the chock cover without gasket.
- Tighten evenly four equally spaced cap screws, until the cover is uniformly seated against the side face of the chock, and cups and cup spacers abut each other.

- Measure the width of the gap between the cover and the chock and establish the gasket or metallic shim set final thickness.
- Remove the cover, insert the gasket or metallic shim set of required thickness and mount the cover.
- Push the labyrinth ring (heated in an oil bath) onto the roll neck.
- Align the chock with the shaft.
- Mount the seal neighboring the shaft shoulder and push the chock onto the roll neck with side E forward until side E of the double cone abuts the labyrinth ring.
- Mount the remaining seal, spacer (A), nut (B) and split clamping ring (C) into position.
- Tighten the nut until it abuts the clamping ring and the spacer abuts the bearing cone.
- Loosen the nut in order to leave an appropriate axial clearance, which enables free cone rotation and prevents wear to the cone faces.

## DISMOUNTING

If the bearing has to be dismantled for inspection and maintenance, dismantling will be performed in the reverse order of mounting. It is important to use appropriate tools and follow the above instructions and recommendations to avoid bearing damage.

