



RKB Multi-Level Quality Control System for Rolling Bearings

CONTENTS

1 INTRODUCTION	3
2 RKB MULTI-LEVEL QUALITY CONTROL SYSTEM	4
2.1 Raw material supplier quality control	4
2.2 Pre-process quality control	6
2.3 In-process quality control	10
2.3.1 Forging quality control	12
2.3.2 Heat treatment quality control	12
2.3.3 Machining quality control	13
2.4 Post-process quality control	14
3 ADDITIONAL QUALITY CERTIFICATES	16
4 SPECIAL QUALITY PROTOCOLS	19
5 CONCLUSIONS	20

1 INTRODUCTION

In this paper the multi-level quality control system for rolling bearings developed and implemented by the RKB Group is presented in detail. Along with state-of-the-art manufacturing technology, a well-organized quality control system is the other key element in the production of reliable and high performance products.

Our quality control program is rooted in RKB top management's insistence on quality and encompasses controls performed on multiple levels, from raw material procurement, through pre-process and in-process operations to post-process check activities (Fig. 1).

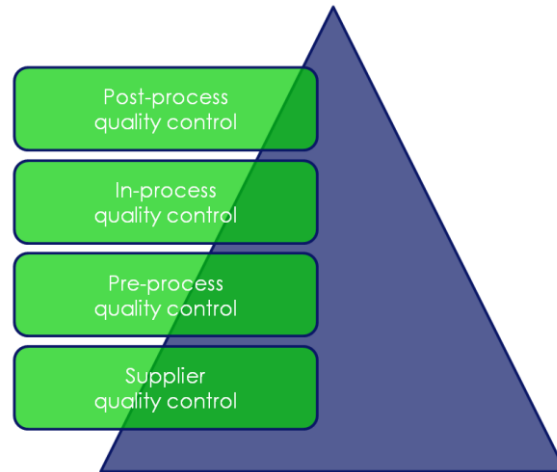

Fig. 1 – RKB Multi-level quality control system

As a part of the RKB Technical Division, the Quality Control Bureau is the operational structure dedicated to creating quality procedures and performing tests and measurements with the objective of issuing the quality certificates throughout the manufacturing process. Its organizational structure is presented in Fig. 2 and will be described thoroughly in the following.

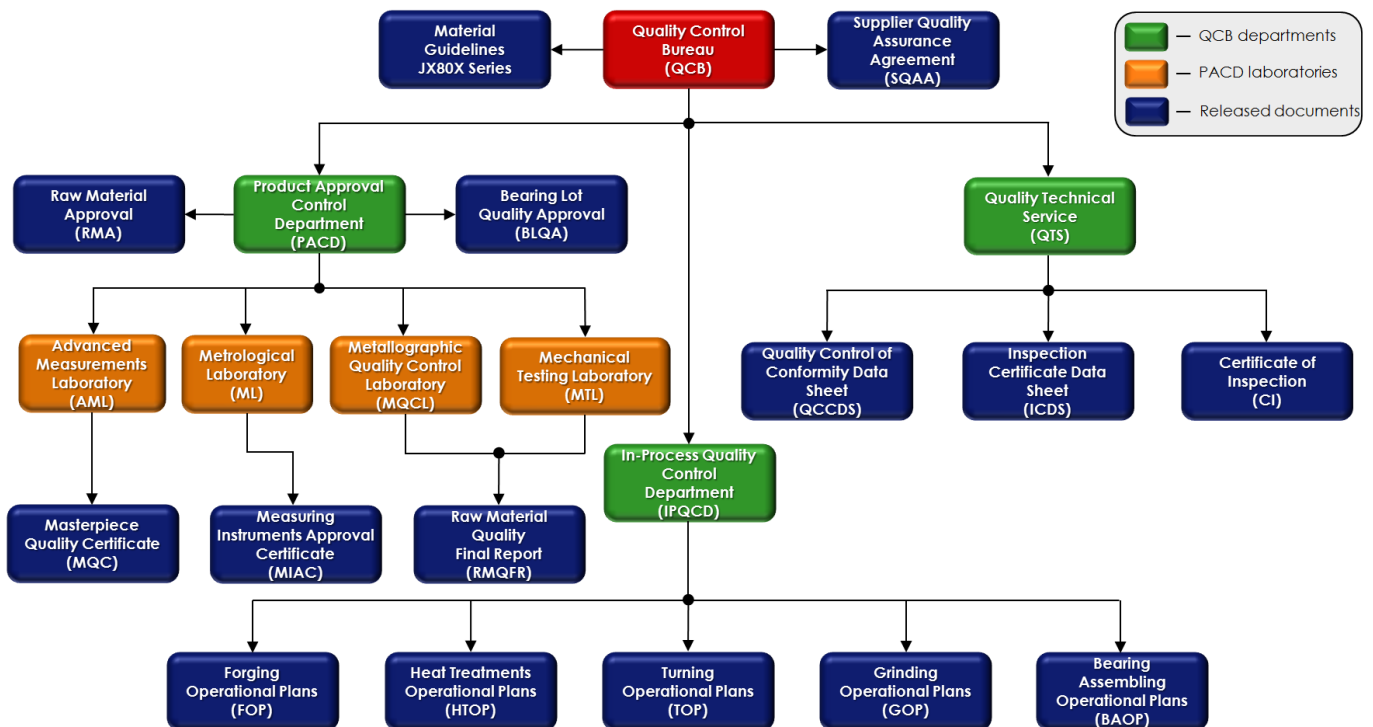

Fig. 2 – RKB Quality Control Bureau

2 RKB MULTI-LEVEL QUALITY CONTROL SYSTEM

2.1 Raw material supplier quality control

The RKB Quality Control Bureau first comes into play during the raw material selection process. The choice of bearing steel is extremely important for bearing end quality, as this is largely depending on the technology used to produce steel (Fig. 3). This is particularly true for large size high-tech bearings, which are the core business of RKB, since the compliance to the international reference standards is significantly more complex and critical for bars with diameter higher than 200 mm and ingots.

Of course, it is of paramount importance to RKB to provide its customers with products of the highest possible reliability and this necessarily implies the selection and use of only high-class raw materials. Obtaining the Supplier Quality Assurance Agreement from the RKB Group requires the following steps on behalf of the steel supplier:

- acceptance and adoption of the RKB Material Guidelines JX80X Series;
- official ISO 9001, OHSAS 18001 and ISO 14001 certifications as far as quality, safety and environmental management systems are concerned;
- passing of periodic quality audits.

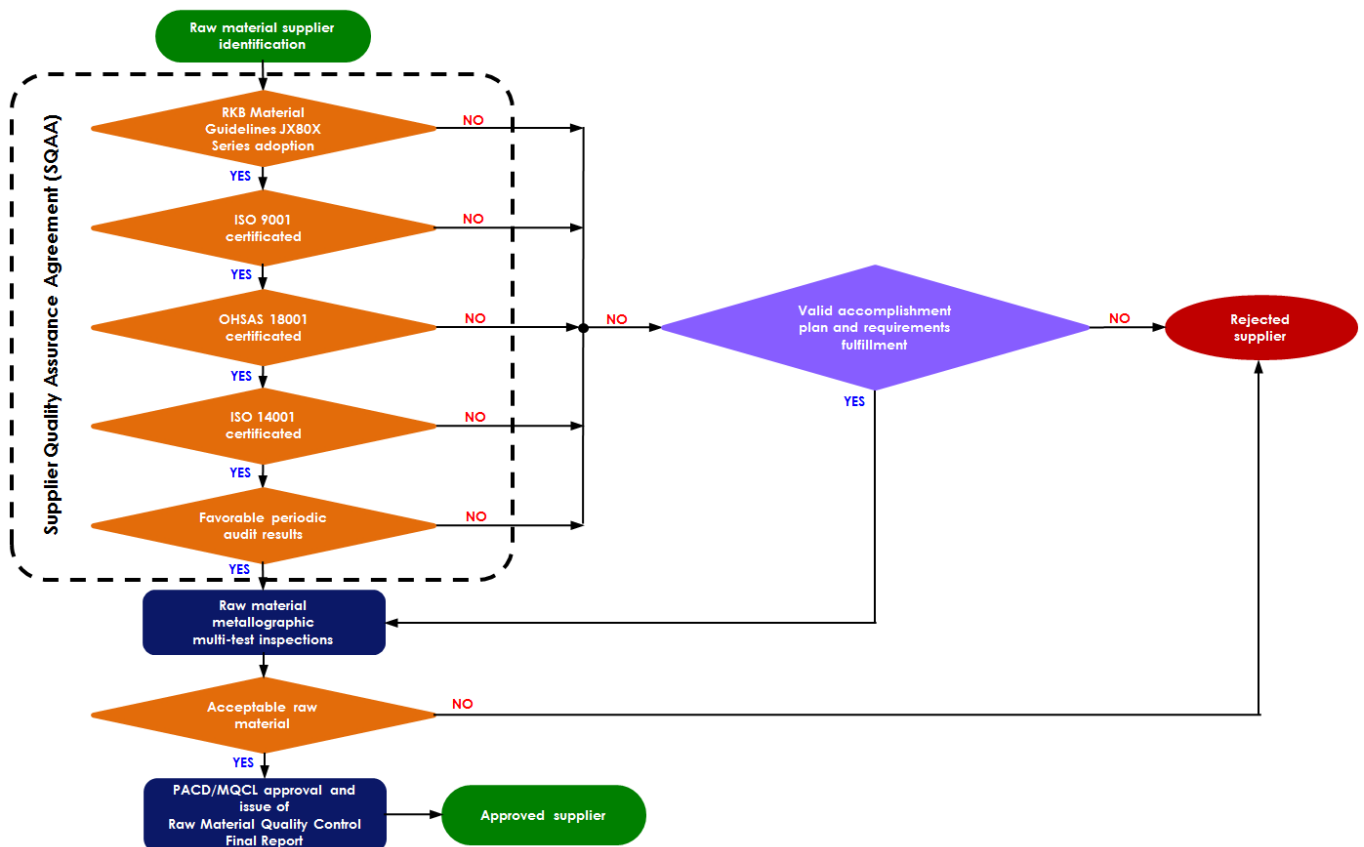

Fig. 3 – Raw material supplier selection process

The raw material quality control performed by RKB applies to both through-hardened and case-hardened steels and is based on multi-test inspections (Fig. 4), according to our Material Guidelines. These multi-test inspections strictly follow the applicable international standards and include: raw material chemical composition analysis, macro- and micro-structure inspections, mechanical properties determination and the Raw Material Quality Control Final Report issue for lot traceability. This final report is released by the Metallographic Quality Control Laboratory and the Mechanical Testing Laboratory, which are parts of the RKB Product Approval Control Department. Also, periodically, according to the RKB internal protocols, all of the measuring instruments and devices are metrologically checked by our Metrological Laboratory.

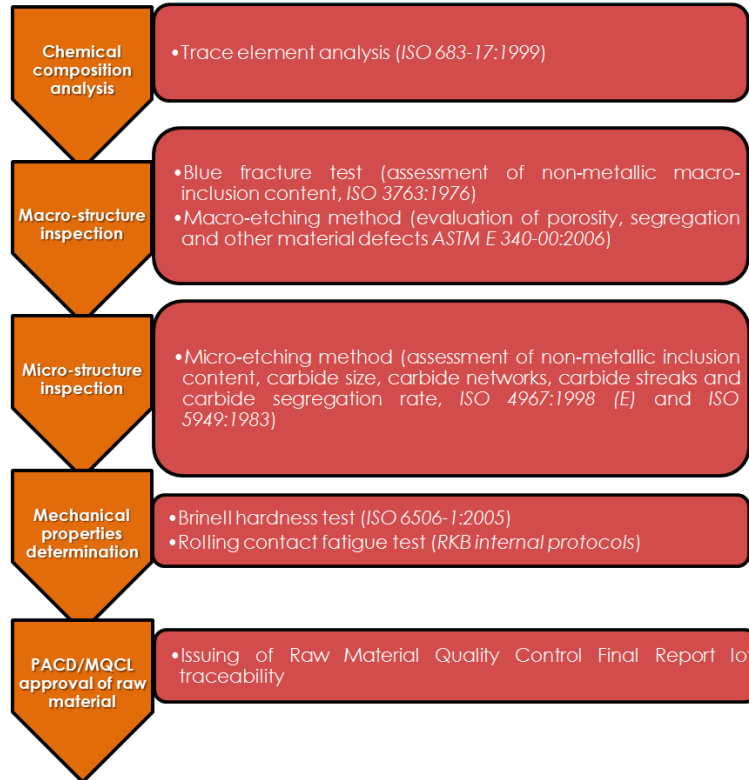

Fig. 4 – RKB raw material metallographic multi-test inspection protocol

The RKB Metallographic Quality Control Laboratory (Fig. 5) performs regular checks on the incoming raw materials. Our advanced equipment and experienced personnel make possible the achievement of one of the most important tasks: the correct quantification of steel cleanliness.



Fig. 5 – RKB Metallographic Quality Control Laboratory

Life prediction test is another important task regularly accomplished by our Mechanical Testing Laboratory to approve any new supplier of raw materials. By way of example, a contact fatigue life test was carried out to check the quality of the steels proposed by five potential raw material suppliers. The material test specimens were annealed and manufactured as washers, hardened in a gas protected electro-furnace between 835 and 845 °C, and finally tempered between 150 and 160 °C for 3 hours.

The evaluation was conducted in a life prediction testing rig (Fig. 6) with a maximum contact stress of 4200 MPa and a maximum speed of 2040 rpm. Each of the five testing groups contained 16 test specimens. For each group, the tests were performed till the fatigue failure of all specimens. The test results listed in the table and depicted in the graph bar (Fig. 7) point out that the test specimens of the first supplier presented the highest values for both rating life and average life.



Fig. 6 – Ball-on-washer life prediction testing rig

Steel supplier	Weibull coefficient	Rating life	Average life	Life ratio	
		L_{10}	L_{50}	$L_{10}/L_{10\text{ supp2}}$	$L_{50}/L_{50\text{ supp2}}$
		Million of revolutions			
Supplier 1	1.6729	0.7570	2.3341	1.86	1.39
Supplier 2	1.3305	0.4078	1.6802	1	1
Supplier 3	1.2495	0.4992	2.2547	1.22	1.34
Supplier 4	1.4811	0.5738	2.0474	1.41	1.22
Supplier 5	1.3548	0.5557	2.2323	1.36	1.33

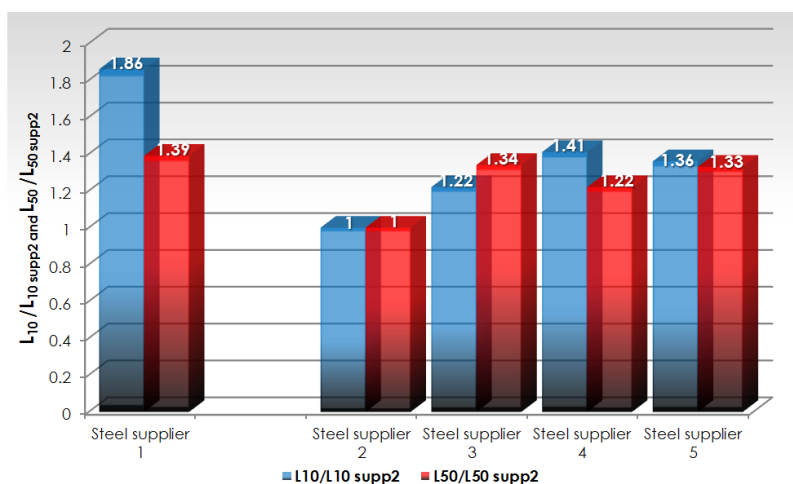

Fig. 7 – Results of contact fatigue life test

2.2 Pre-process quality control

After the positive results of quality controls on raw materials, the pre-process control level comes into play. This level mainly involves the use of masterpieces for rings and rollers manufacturing. The masterpieces are extremely accurate bearing component prototypes that, having high quality machined surfaces and very tight ranges of dimensional and geometrical tolerances, are used to calibrate the measuring instruments involved in the production process.

The two flowcharts in Fig. 8 and Fig. 9 thoroughly describe the main processes and the quality controls involved in the manufacturing of ring and roller masterpieces.

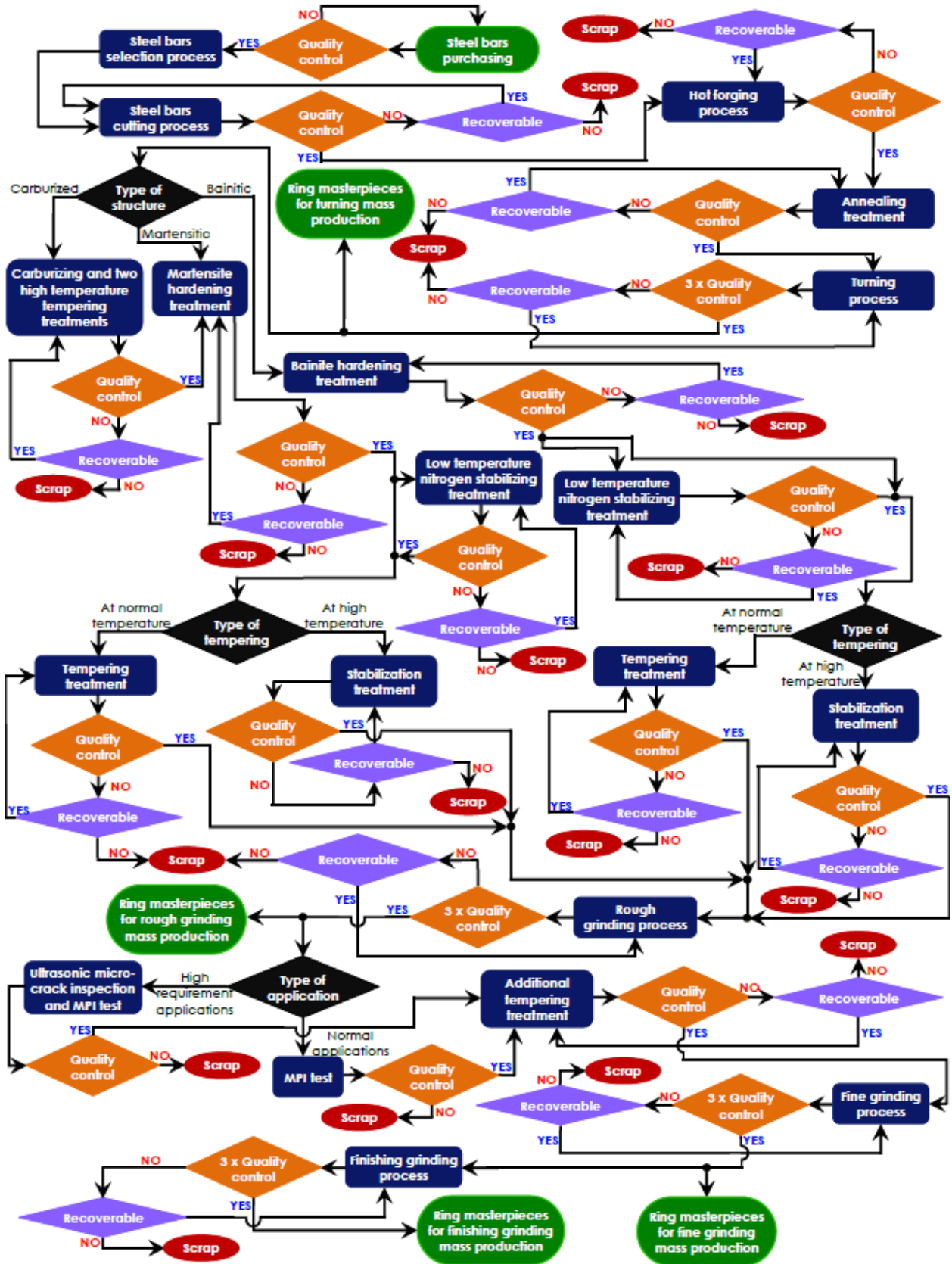

Fig. 8 – RKB rolling bearing rings masterpieces production

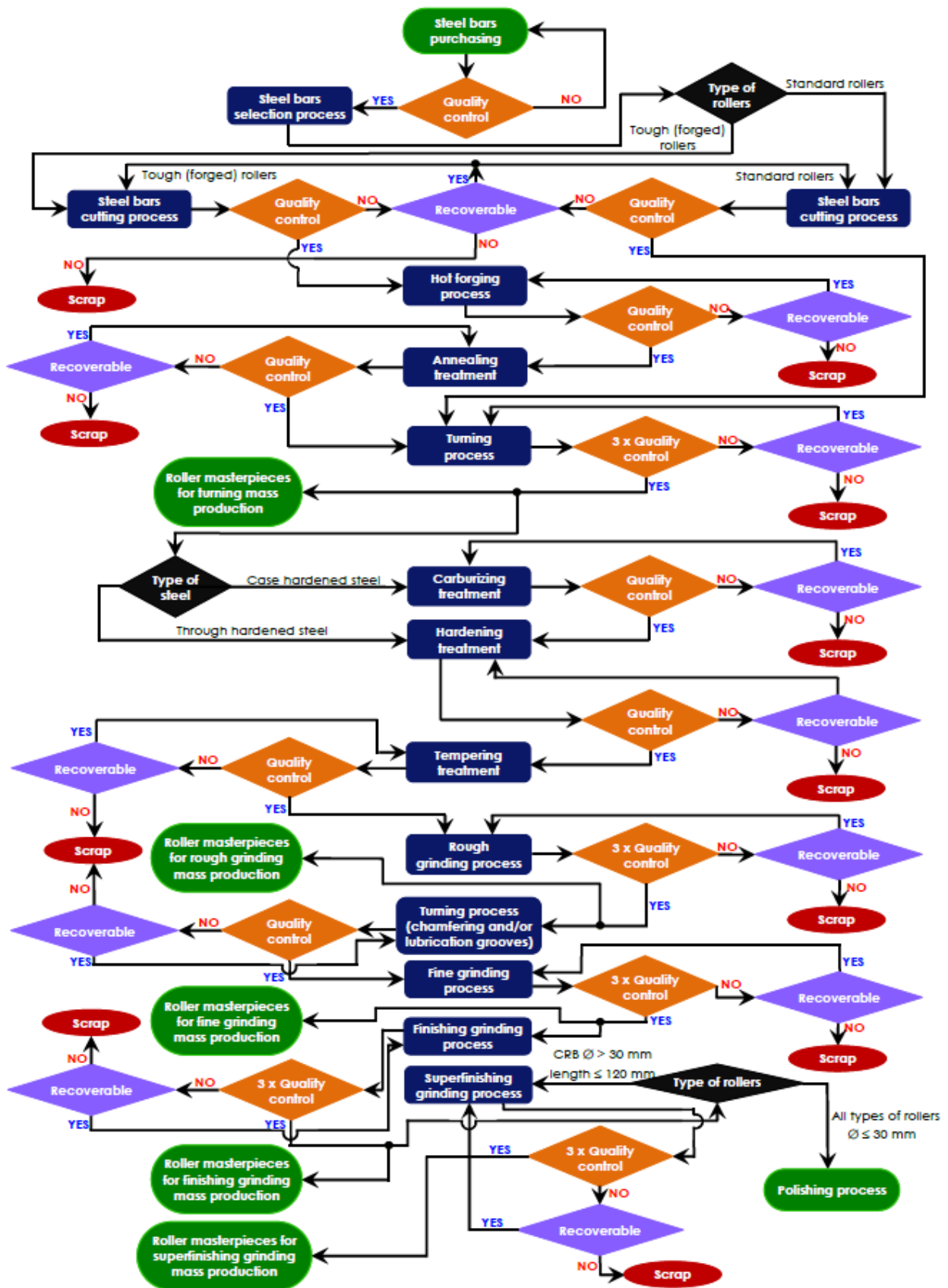

Fig. 9 – RKB rolling bearing rollers masterpieces production

RKB's decision of using masterpieces for all product lines rises from the need for more and more precise, and therefore reliable, products. The masterpieces are produced in the RKB Executive Headquarters and Technological Center (Fig. 10) in Balerna, Switzerland, by means of ultra-high precision machine tools endowed with the latest technologies.

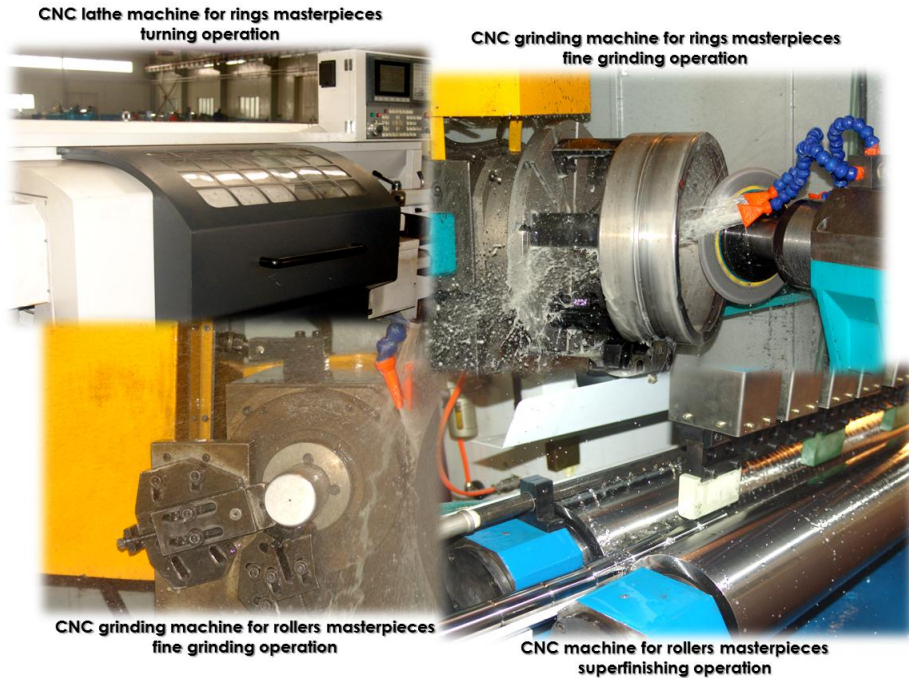

Fig. 10 – Machine tools in RKB Masterpiece Workshop in Switzerland

The use of masterpieces permits to reduce manufacturing time and errors, ensuring steady top quality at the same time. Before being used during the in-process checks, the ring and roller masterpieces for every machining operation are at first strictly controlled by the related workshop operator and by an inspector, and finally approved by the Advanced Measurements Laboratory (Fig. 11). The final approval implies accurate measurements of the dimensions, and geometrical and surface quality parameters using the most modern measuring instruments, in a strictly controlled environment, and according to the reference international standards.



Fig. 11 – RKB Advanced Measurements Laboratory

2.3 In-process quality control

The in-process quality controls refer to the controls performed throughout the strictly speaking “bearing manufacturing process”. They ensure consistency in product quality during all stages of bearing production by adopting modern quality control techniques in forging, heat treatment, machining and assembly.

The two flowcharts from Fig. 12 and Fig. 13 present the production processes, and the related quality control steps (in orange), involved in rolling bearing rings and rollers manufacturing, starting from steel bar selection and finishing with bearing assembly and storage.

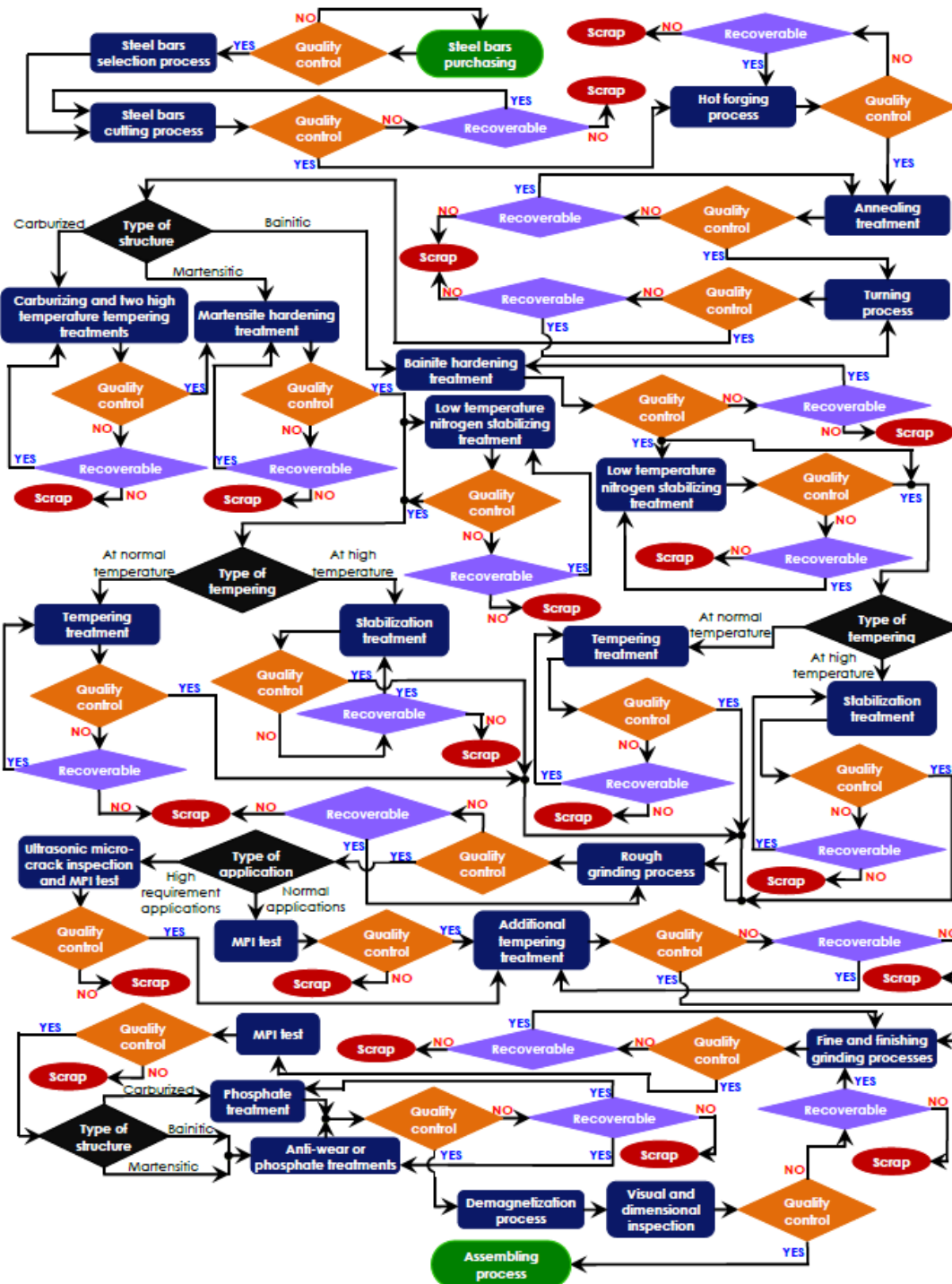

Fig. 12 – RKB rolling bearing rings production

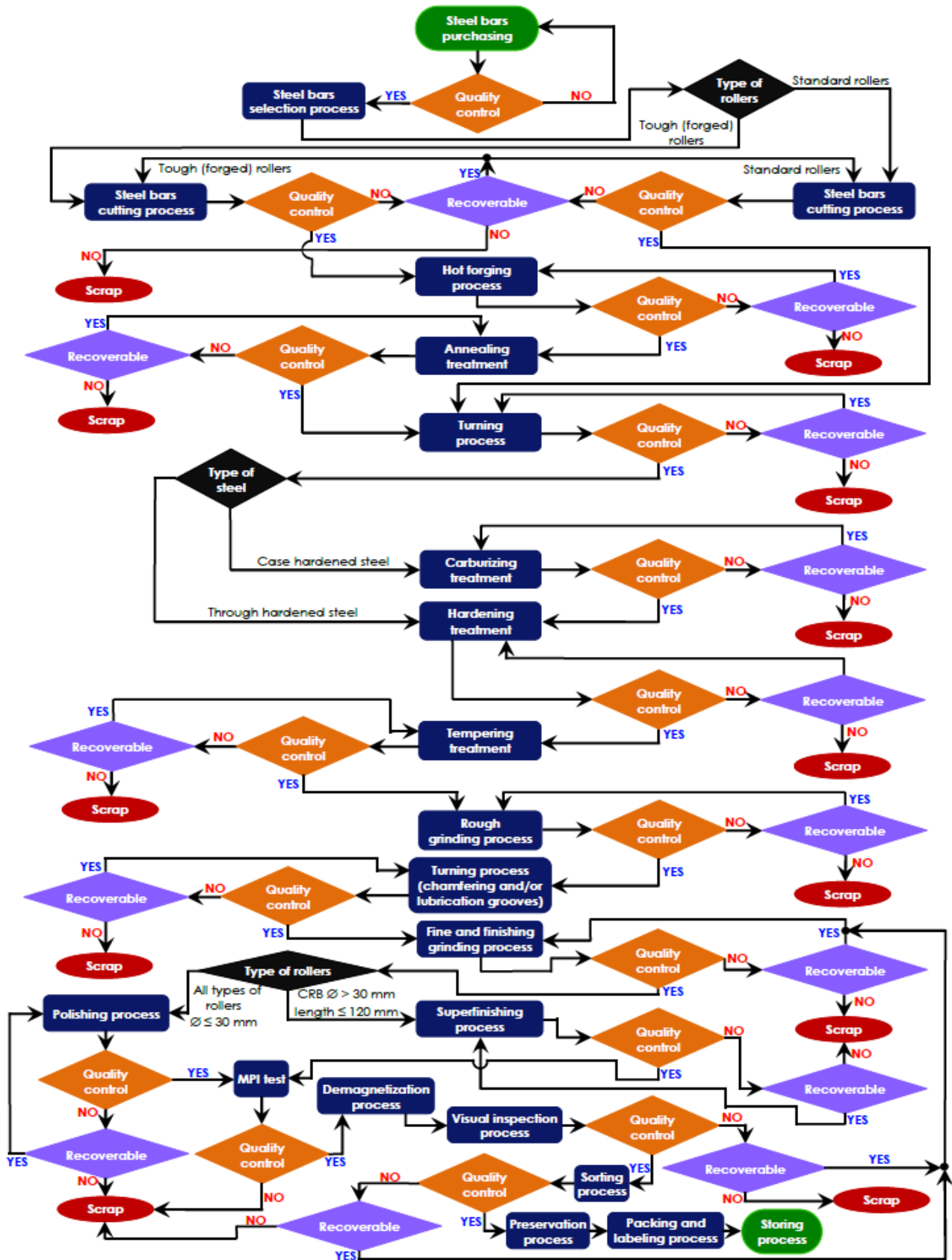

Fig. 13 – RKB rolling bearing rollers production

2.3.1 Forging quality control

More in depth, after the raw material approval by the Product Approval Control Department, the forging process begins, encompassing steel bar or ingot cutting, heating, upset forging or upset pressing and rolling. Every steel bar or ingot lot enters the forging area accompanied by the related Control Data Sheet emitted by our Raw Material Warehouse that specifies the type and quality of steel and the dimensions and weight of the material. In this way, our technicians, according to the Forging Operational Plan, can easily set the heating temperature, which is a crucial parameter for this process (Fig. 14). After forging, all the components are dimensionally checked and the relevant data are digitally recorded.

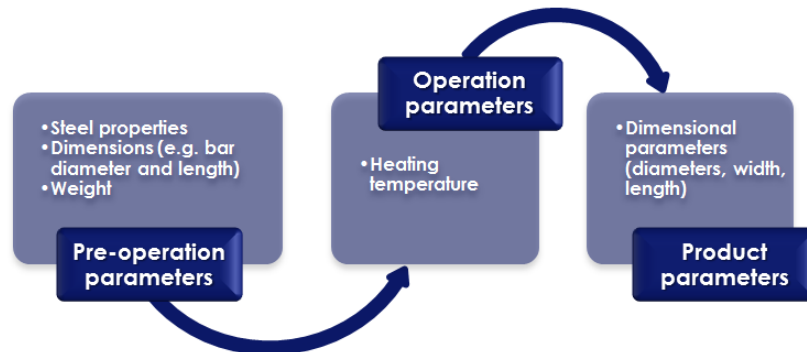

Fig. 14 – Forging quality parameters

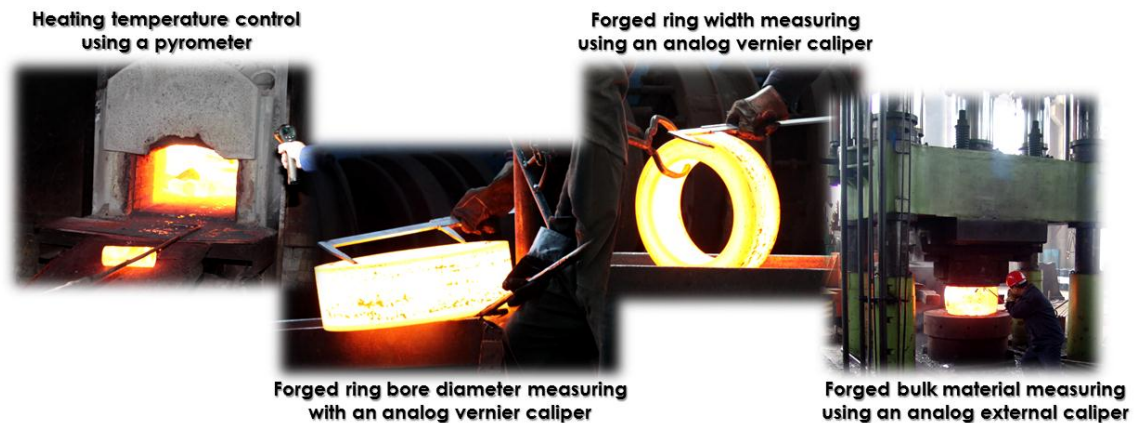

Fig. 15 – Measurement of forging quality parameters

2.3.2 Heat treatment quality control

All RKB bearing steels are in-house heat treated in order to obtain optimum mechanical properties. In addition to the conventional thermal cycles, RKB can carry out two special heat treatments on its products: RKB Bainite Treatment (HB) for decreasing ring crack incidence and RKB Dimensional Stabilization Treatment (S) for ring dimensional stability up to an operating temperature of 350 °C. Finally, two thermo-chemical surface treatments are available: RKB Anti-Wear Treatment (AWT), essential to reduce the metal-to-metal friction between contact surfaces, and RKB Phosphate Treatment (PT), suitable for bearings operating in highly corrosive environments.

Bearing components enter the heat treatment area accompanied by the related Control Data Sheet issued by the previous workshop, where the steel type and the dimensions of the parts are specified. Taking into consideration these parameters, furnace atmosphere, treatment time curve and quenching conditions (Fig. 16) are programmed according to the Heat Treatment Operational Plan.

After heat treatment, a series of parameters concerning form, hardness and microstructure are checked (Fig. 17). If test results are not in accordance with the specifications set by the applicable international standards and RKB internal protocols, the cause of error is determined and all suspected components, if recoverable, are treated once again, after the corrective action is applied. All the parameters specific to every lot are recorded in a special digital database.



Fig. 16 – Heat treatment quality parameters

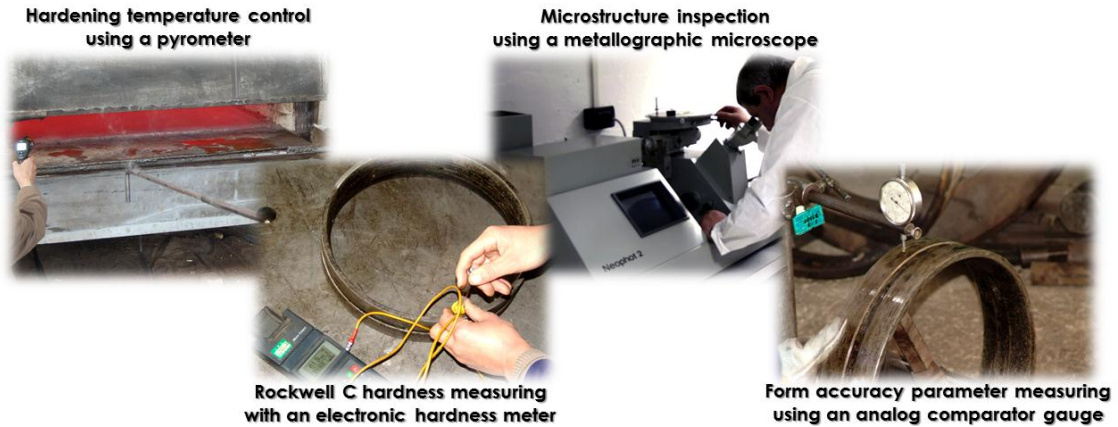

Fig. 17 – Measurement of heat treatment quality parameters

2.3.3 Machining quality control

The quality controls connected to the machining process starts with the set-up of every machine tool according to the RKB production method. These settings are verified at regular breaks during production. At the end of every turning and grinding operation of rings and rollers, a check for compliance with the tight tolerances of masterpieces is performed.

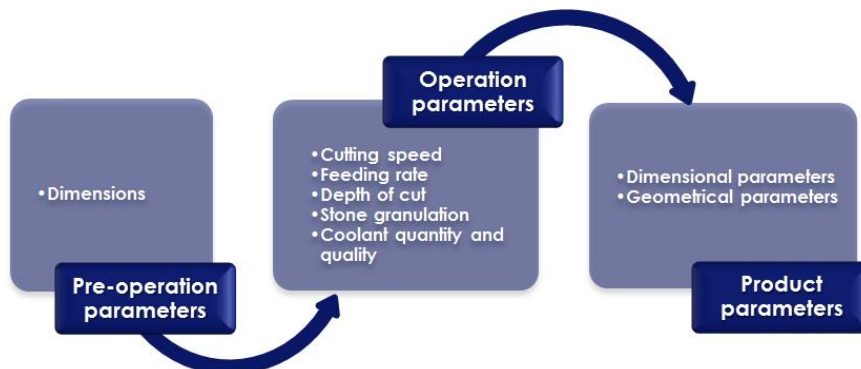

Fig. 18 – Machining quality parameters

A series of dimensions and geometrical and surface quality parameters (Fig. 18) are controlled by an integral calibrated system (Fig. 19) that ensures all measures are within the allowable tolerances and in accordance with RKB internal manufacturing drawings. This system guarantees the quality of every lot before it is transferred to the next workshop.

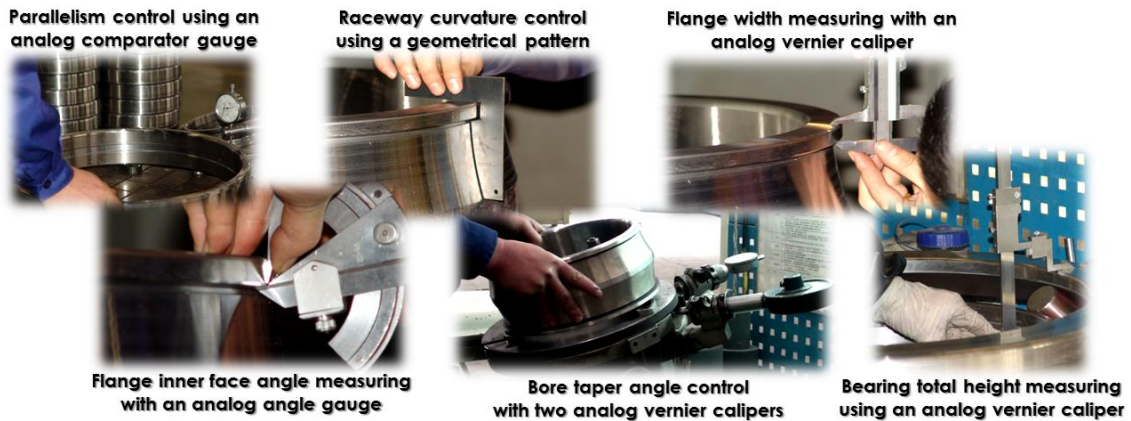

Fig. 19 – Measurements within integral calibrated system

Specific non-destructive controls like the Magnetic Particle Inspection, for detecting superficial micro-cracks, and the Ultrasonic Micro-Crack Detection, for under-surface micro-cracks location, are regularly performed on rings and rollers during the production process (Fig. 20).

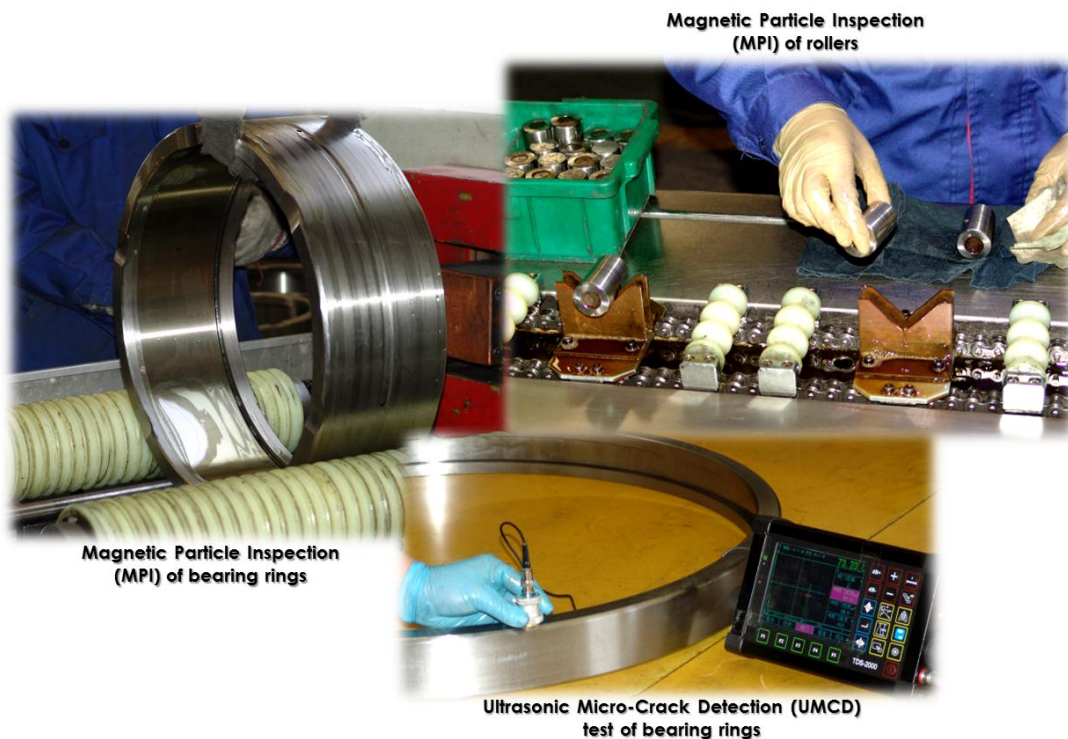

Fig. 20 – Specific non-destructive controls

Moreover, a visual check of the parts ready for assembly is always carried out to avoid any noticeable anomaly. Selections of rolling elements and rings in groups of defined grade for correct matching are made by the RKB Assembling Department in order to obtain the radial internal clearance specified by the pertinent bearing technical drawing.

2.4 Post-process quality control

After accomplishing the in-process cycle, bearing samples are subjected to the post-process controls, which encompass both non-destructive tests (visual, dimensional, geometrical and surface quality control, and mechanical properties determination) and destructive tests (chemical composition, and macro- and micro-structure evaluation Fig. 21).

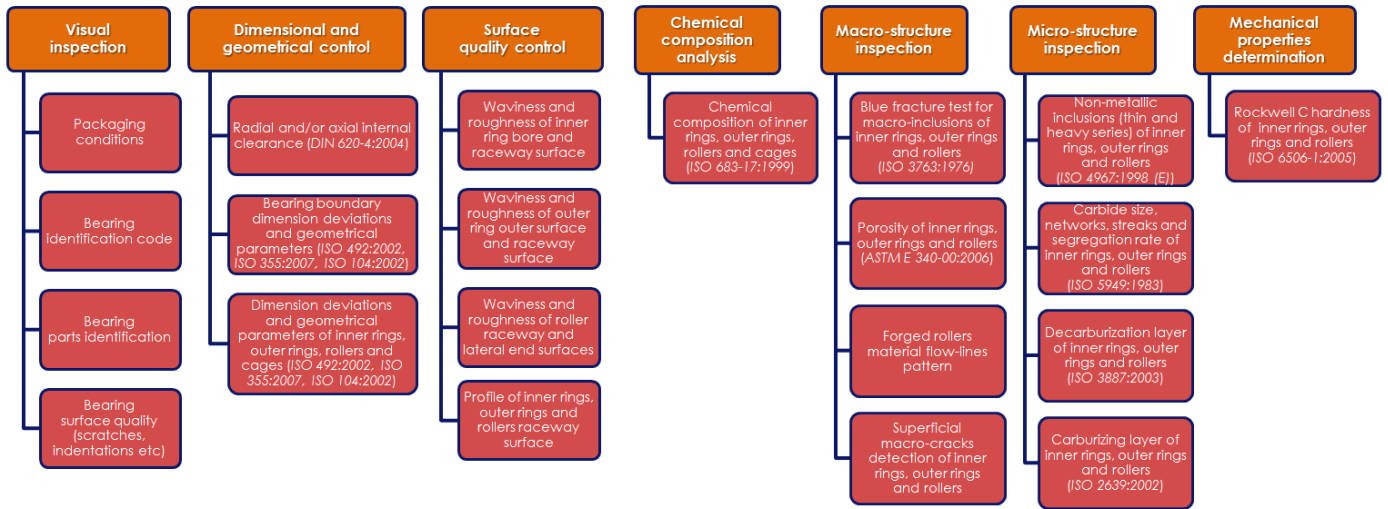

Fig. 21 – RKB rolling bearing post-process multi-test inspections

These multi-test inspections are regularly performed by the RKB Advanced Measurements Laboratory (Fig. 22) and Metallographic Quality Control Laboratory by means of the latest measuring instruments in strictly controlled environments, according to the applicable international standards. In more detail, for dimensional, geometrical and surface quality controls, our engineering team, among others, makes use of COORD 3 coordinate measuring machine, Talyrond 131, Talyrond 73, Form Talysurf Intra and other special tools.

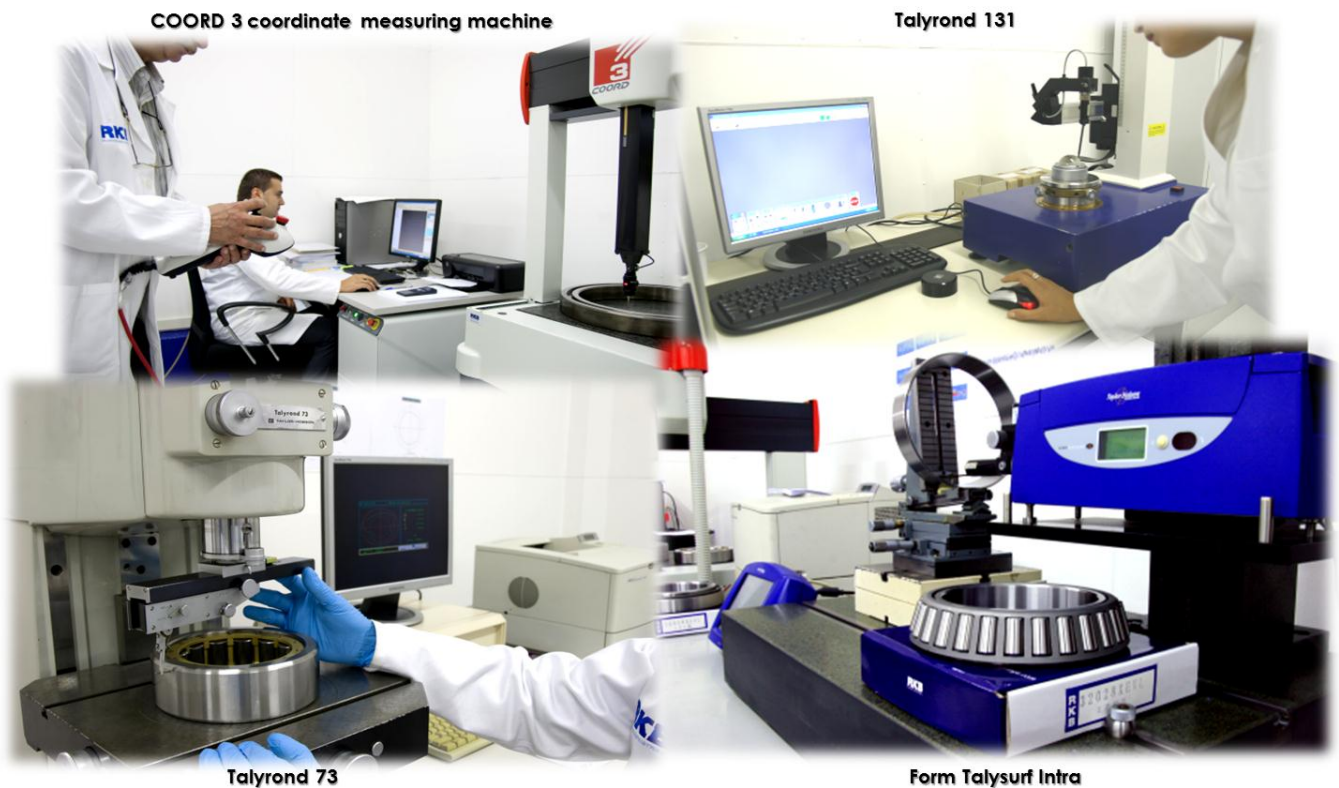

Fig. 22 – RKB Advanced Measurements Laboratory

For the metallographic and mechanical properties assessment of bearing components, we use, among others ARL 4460 spectrometer analyzer, Neophot 2 metallographic microscope equipped with a high resolution digital camera, Handy Esatest digital hardness tester and other dedicated equipment (Fig. 23).



Fig. 23 – Metallographic and mechanical measuring equipment

3 ADDITIONAL QUALITY CERTIFICATES

On customer request, the Quality Technical Service of RKB is entitled to release additional quality certifications. The QCCDS or Quality Certificate of Conformity Data Sheet (Fig. 24) certifies that the dimensional and running accuracy parameters of RKB products are in conformity with the relevant international standards. Moreover, it offers supplementary information on the bearing tolerances, which can help customers manufacture the conjugated components (housing and shaft) according to the application requirements.

The ICDS or Inspection Certificate Data Sheet (Fig. 25) is a technical certificate that may turn out to be necessary for those customers working in industries where specific regulations apply. It works as a third party certification and encompasses a visual, dimensional and hardness evaluation of the bearing.

Moreover, every packed bearing is delivered with a Certificate of Inspection, which, besides attesting the accordance with the applicable standards, lists some precautions for handling, lubrication and use of RKB products.



QUALITY CERTIFICATE OF CONFORMITY DATA SHEET

Bearing Specification:
L313008F2CIIZBAH

Serial No.:
6 B

Unit: mm

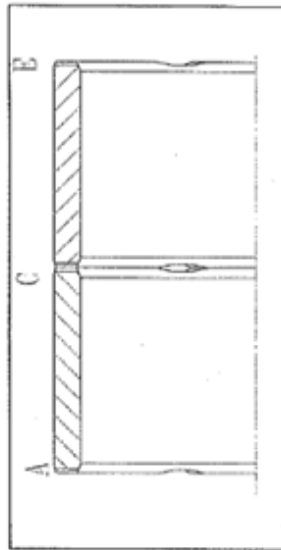

Bore Specification	
Max	Min
690.000	689.945

Bore Actual	
689.980	— 689.960

dmp measured actual value	689.970
F measured actual value	767.400
Kia measured actual value	0.250
Height over Assembly	714.860

Inspector: RKB-01

RKB

T3

Plant

Fig. 24 – QCCDS or Quality Certificate of Conformity Data Sheet



INSPECTION CERTIFICATE DATA SHEET

Bearing Specification: TDONASW 442210 AAZBBT2B	Lot/Serial No.: 14
---	--------------------

Unit: mm

Ref.:	O.D. Specification	
	Max	Min
	200.00	199.97
O.D. Actual		
199.98		

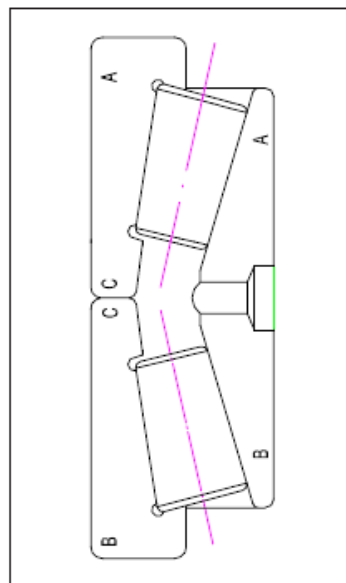

Bore Specification	
Max	Min
140.00	139.975
Bore Actual	
139.991	

BEP	0.25 / 0.30	0.26
Width over Cup	73.00 / 73.05	73.02
Width over Cones	93.67 / 93.82	93.59
Visual check	OK	
HRC/Hardness	Inner 61.6	Outer 61.0 Rollers 61.9

Notes	_____ _____ _____
-------	-------------------------

Inspector: Manolescu V.	Date: 28.05.2010
-------------------------	------------------

RKB BEARINGS	Technical Team Unit
--------------	---------------------

RKB-ICDS-PLS-127

RKB Europe SA
Executive Headquarters and Technological Center

Engineered in Switzerland
Technological Bearings

Fig. 25 – ICDS or Inspection Certificate Data Sheet

4 SPECIAL QUALITY PROTOCOLS

For specific classes of applications, the RKB Group has developed supplementary quality protocols, among which Victory Line, Wind Class, ROVSX, for vibrating machinery, and Made to Order or Application Optimized Bearings (Fig. 26).

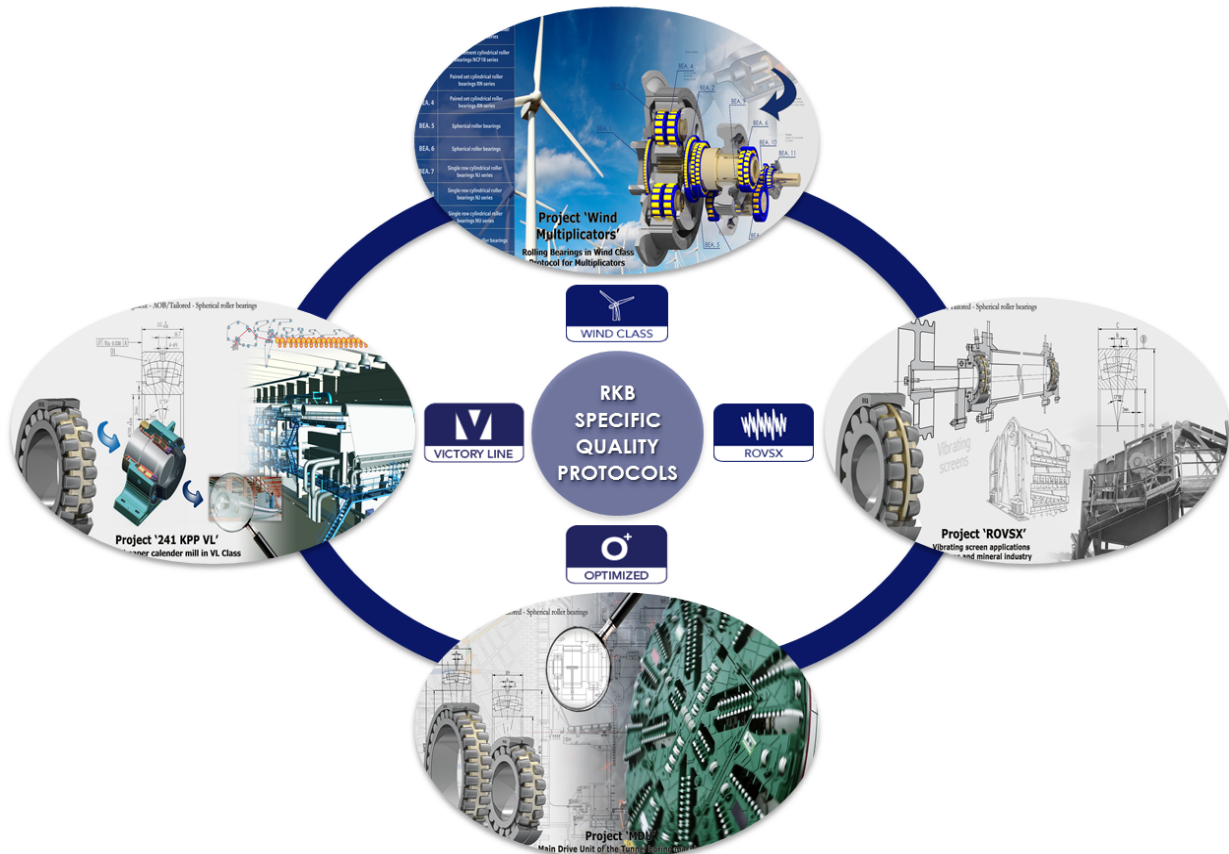

- The best improved bearing steel;
- Latest knowledge on micro-geometry and surface topography;
- Improved manufacturing technology (high precision machining and special heat treatments).



- Advanced software engineering;
- Advanced material engineering;
- Special heat treatments (bainite treatment - HB and anti-wear treatment - AWT);
- High precision machining.



- Co-engineering and customized/optimized solutions;
- Advanced software engineering;
- Advanced material engineering;
- Improved manufacturing technology.



- Bainite treatment and dimensional stabilization for rings (HB+S1);
- Outer ring guided cage MA design with special open-end design;
- Controlled radial clearance in restricted range;
- Precision class higher than standard for 223 series.

Fig. 26 – RKB Specific Quality Protocols

All these protocols use the latest knowledge on micro-geometry and surface topography, the most advanced software engineering and the best bearing steels, special heat treatments and manufacturing technology.

5 CONCLUSIONS

In the perspective of RKB's total quality policy, all the protocols and procedures followed by our Group are in conformity with ISO 9001 and ISO 14001 and have as guidelines the principles of Total Quality System, Company Wide Quality Control and Quick Response Manufacturing. Besides, at RKB all the employees have to comply with the strict internal code of conduct and all the manufacturing plants are continually audited and homologated by independent international certification bodies and numerous key clients.

In conclusion, the RKB multi-level quality control system for rolling bearings:

- is the operationalization of the total quality policy concept pursued by our company;
- is organized and supervised by the RKB Quality Control Bureau, which is an executive structure of the RKB Technical Division dedicated to managing quality under all respects;
- has the objective of ensuring that the appropriate quality procedures are in place and constantly followed at all levels of organization.

All this contributes to guarantee the superior quality of our products and services. For further information on the quality management system of RKB, please refer to the new General Quality Program (No. GQP0211AE) available on our web site.