

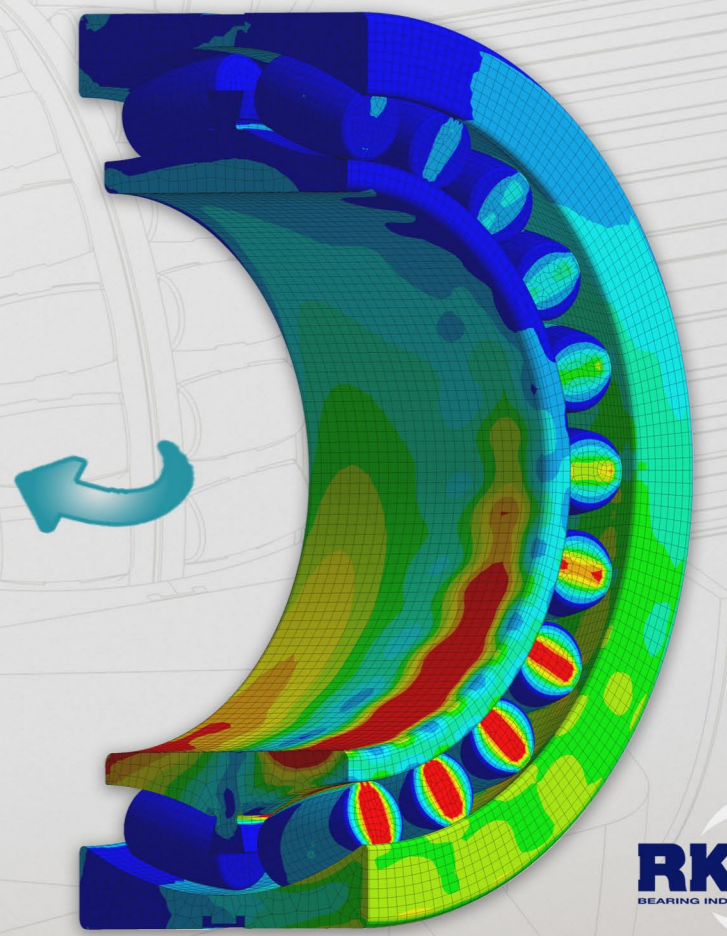

Main bearings: T3 Segment - Spherical roller bearings WOR design

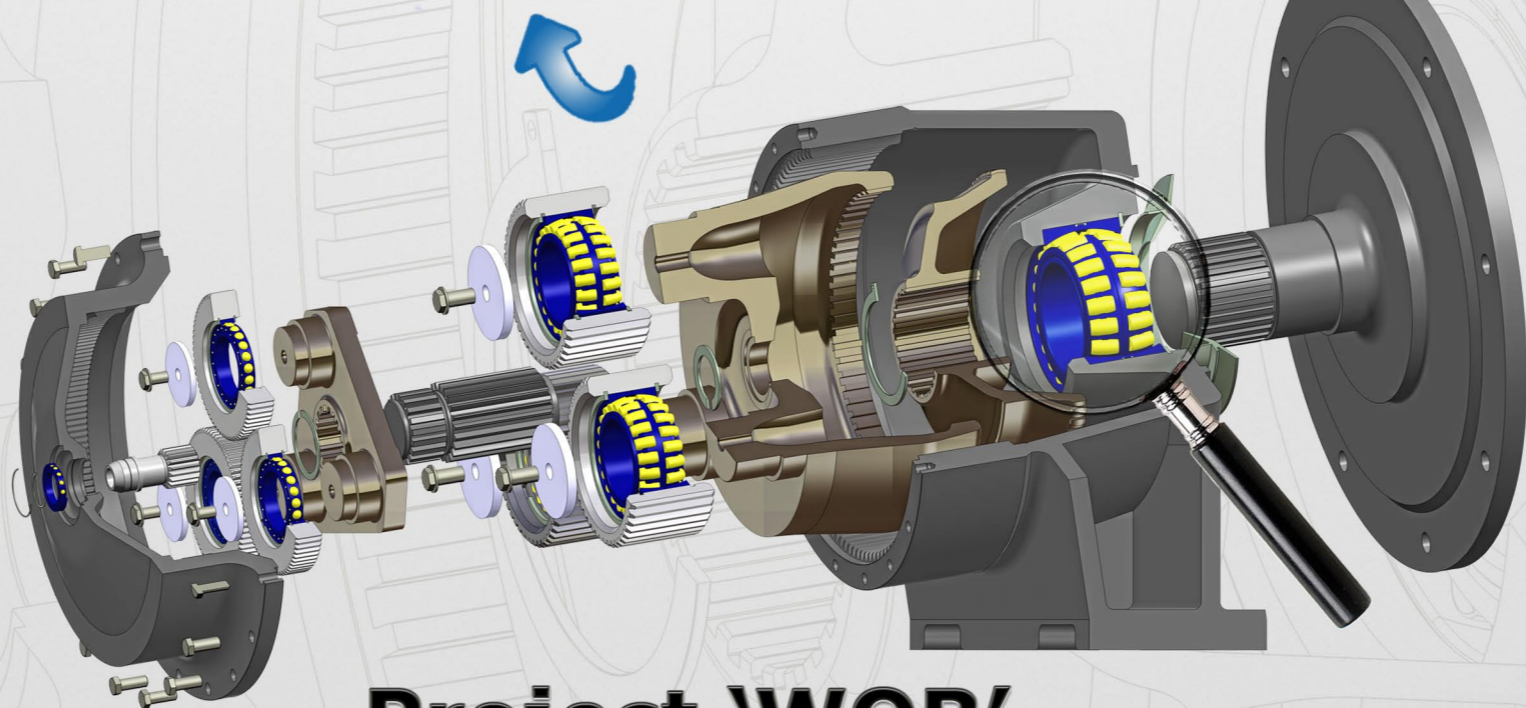

Project 'WOR'
Concrete mixer gearbox

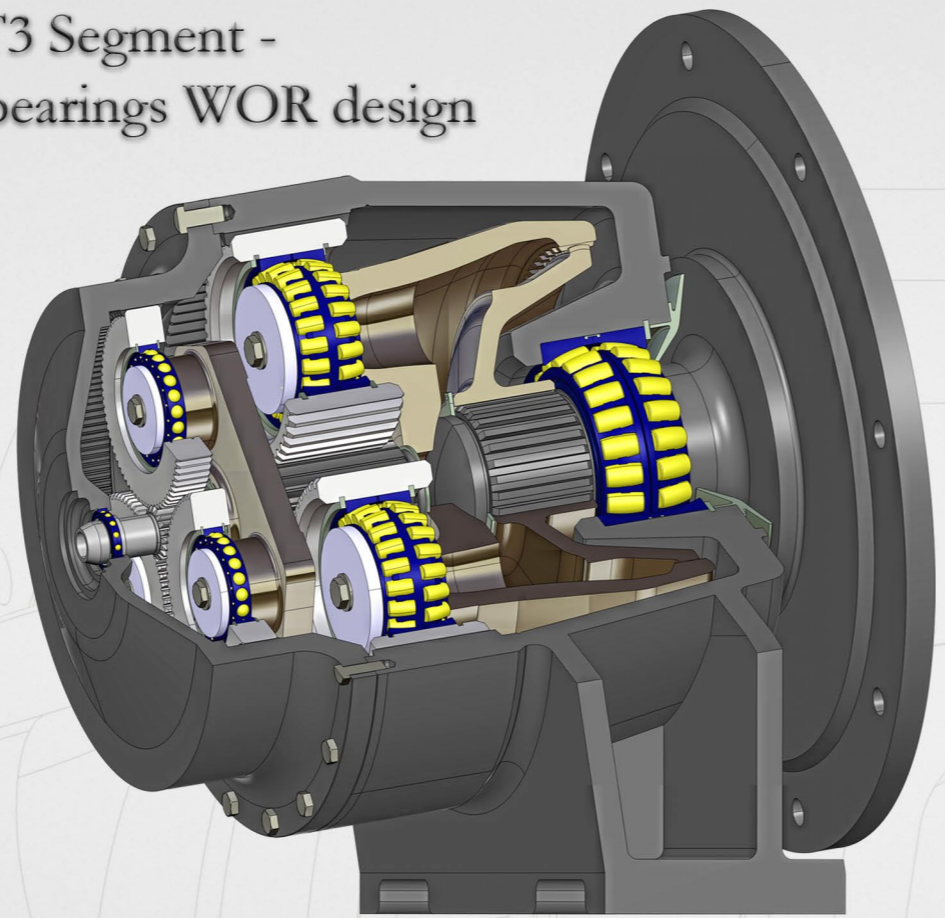
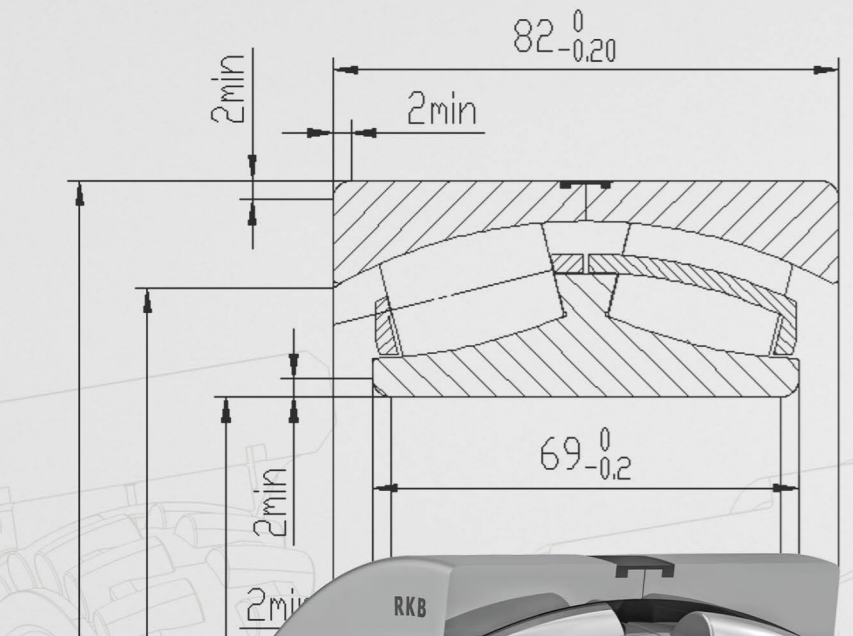

